



SINODRIVE200 AC DRIVE





CONTENTS

Naming Rules	01
Nameplate	01
Product Features	02
SD200 Structure Diagram	04
Basic Wiring Diagram	05
Technical Specification	06
Technical Data	07
SD200Outline Diagram	08
Installation Size	09
Keyboard/Accessory	10
Peripheral Equipment	11
Braking Unit Recommendation	12





Naming Rules

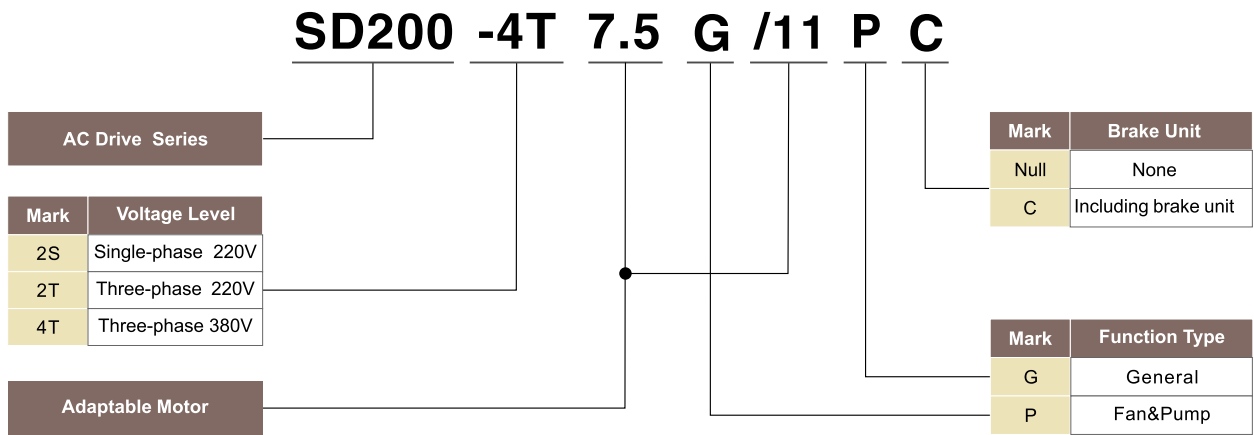

Nameplate

SINOVO CE

MODEL: SD200-4T-5.5G/7.5P C AC Drive model

INPUT: AC3PH 380V 50/60Hz 14.6A/20.5A Rated input voltage, frequency and current

OUTPUT: AC3PH 380V 0~600Hz 13A/17A Rated output voltage, frequency and current

S/N: Bar code

FDLAGCA0A040

SHENZHEN SINOVO ELECTRIC TECHNOLOGY CO.,LTD.
MADE IN CHINA





Product Features

01 Features and Functions

☛ Low frequency and large torque output, VF control mode, under low frequency of 1 Hz 150% load current waveform

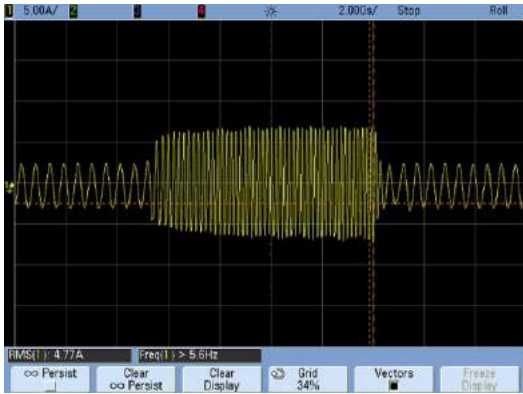

☛ Open-loop vector control mode, under 0.5 Hz 150% load current waveform

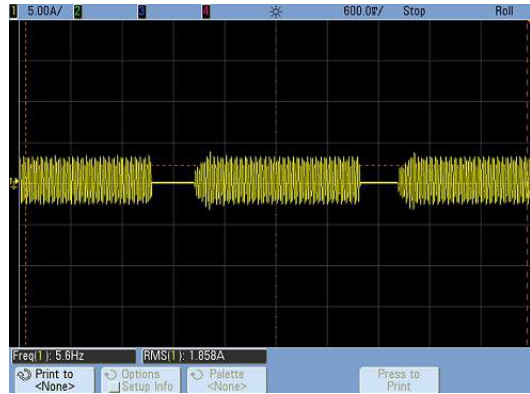

☛ Load feedback energy compensates the voltage reduction so that the AC drive can continue to run in a short time in case of power interruption. When the power input normal, it return to normal operation.

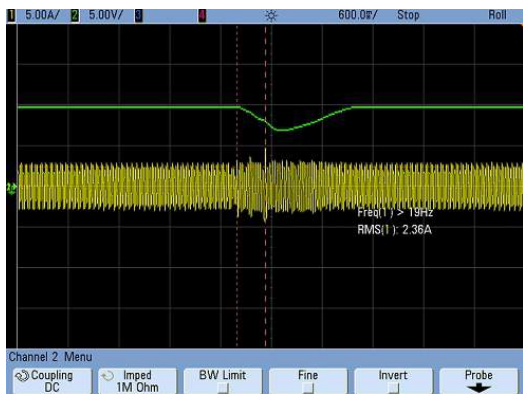

☛ Fast and effective hardware current limiting technology, when the current of each phase is greater than the limit value during detecting, the logic circuit in the 5uS forced to close the PWM output to complete the wave limit control. The following figure is the motor rotor under high speed rotation start-up and three-phase current limiting waveform



☛ In the following figure, the hardware limits of the motor three-phase current is forced to flow through the inner limit point.





Product Features

02 Features and Functions

Multiple motor switch

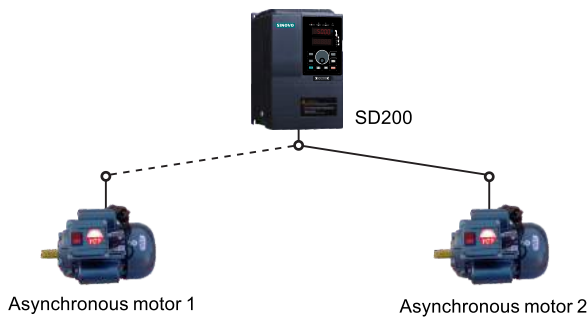

Dual-motor switch enables two separate motors, free switching in the independent control mode..

Motor overheating protection

Select input and output expansion card, analog input AI5 can accept motor temperature sensor input (PT100, PT1000), when the motor temperature is higher than the overheating protection value, the AC Drive fault output will protect the motor properly.

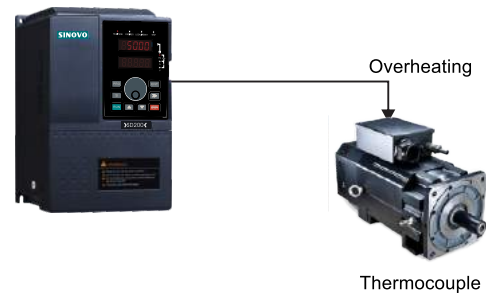

Virtual IO function

SD200 series AC drive possess virtual input/output terminal function. The virtual input/output control is achieved by RS485 communication setting. The function code F05.11 will shift the physical digital input DI terminals to virtual input terminals, its function corresponding to physical terminals function setting.

For example: Enable virtual terminal DI2 as external fault alarm function, set as follows:

F05.11=1, F05.02=9, 3009H=0x0002 (RS485 communication setting)

Digital output terminal Do1, relay output T1, T2 possess flexible output characteristic, after setting corresponding parameter enable validity can be adjusted by communication function freely.

For example: Enable relay T1 action, set as follows:

F06.03=23, 300AH=0x0004 (RS485 communication setting)

Flexible and practical analog input / output ports

- ▶ AI1 ~ AI3 standard virtual analog, AI 2 and AI 3 can set 3 points curve and flexible to use
- ▶ AI 1~AI 3 with factory calibration or user-site calibration of linear curves and the accuracy achieves 20mV.
- ▶ AO1 and AO2 with factory calibration and user-site calibration of linear curves zero drift and gain and the accuracy achieves 20mV.
- ▶ Extension AI5 is isolate input port, it can be used as PT100, PT1000 or 0 + 10v input port.





SD200 Structure Diagram

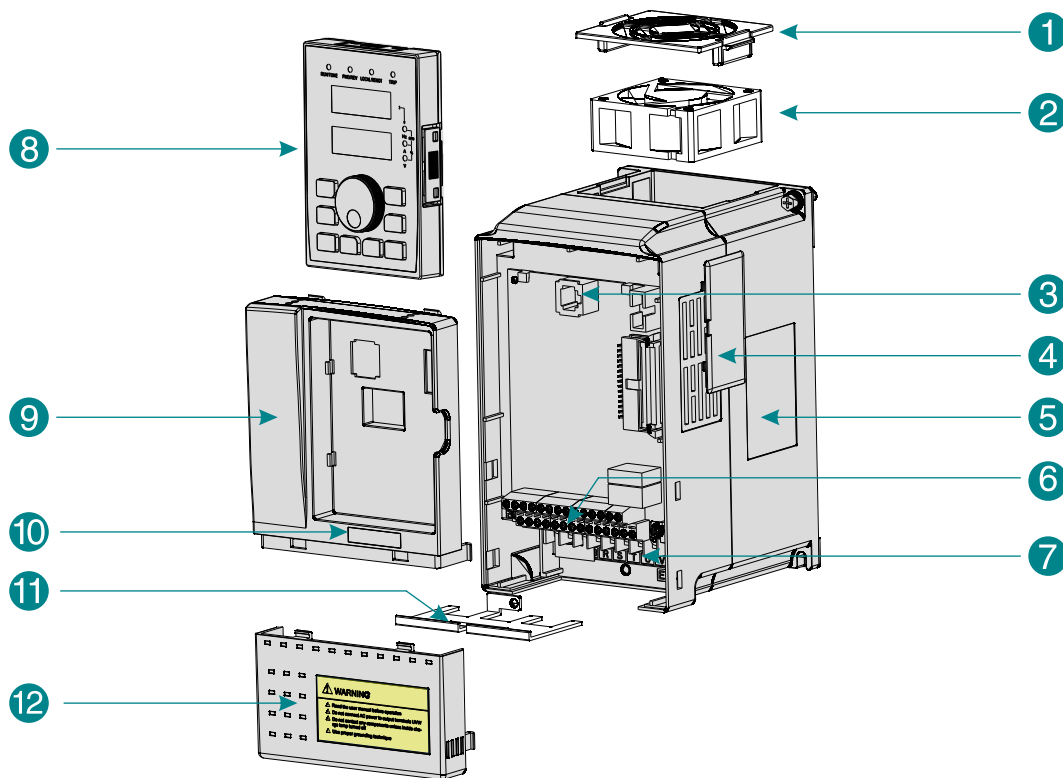

SD200 Product structure diagram (7.5kw, for example)

NO.	Name	Description
1	Fan cover	Protection fan.
2	Cooling fan	See SD200 user manual 8.1 "Definition of Related Terms."
3	Keypad interface	It is used to connect the Keypad.
4	Vents-cover	Optional. with the vents-cover installed, the protection level will increase and the AC drive internal temperature will increase as well so please derating use the AC drive.
5	Nameplate	See SD200 user manual 2.4 "Nameplate"
6	Control terminal	See SD200 user manual 3.3 "Standard Wiring"
7	Main circuit terminal	See SD200 user manual 3.3 "Standard Wiring"
8	Keypad	See Sd200 user manual Chapter4 "Operation, Display and Application Examples."
9	Cabinet-cover	Protect the internal components.
10	Series label	See SD200 user manual 2.3 "Naming rules"
11	Apron	Convenience input and output wiring
12	Lower cover	Protect the internal components





Basic Wiring Diagram

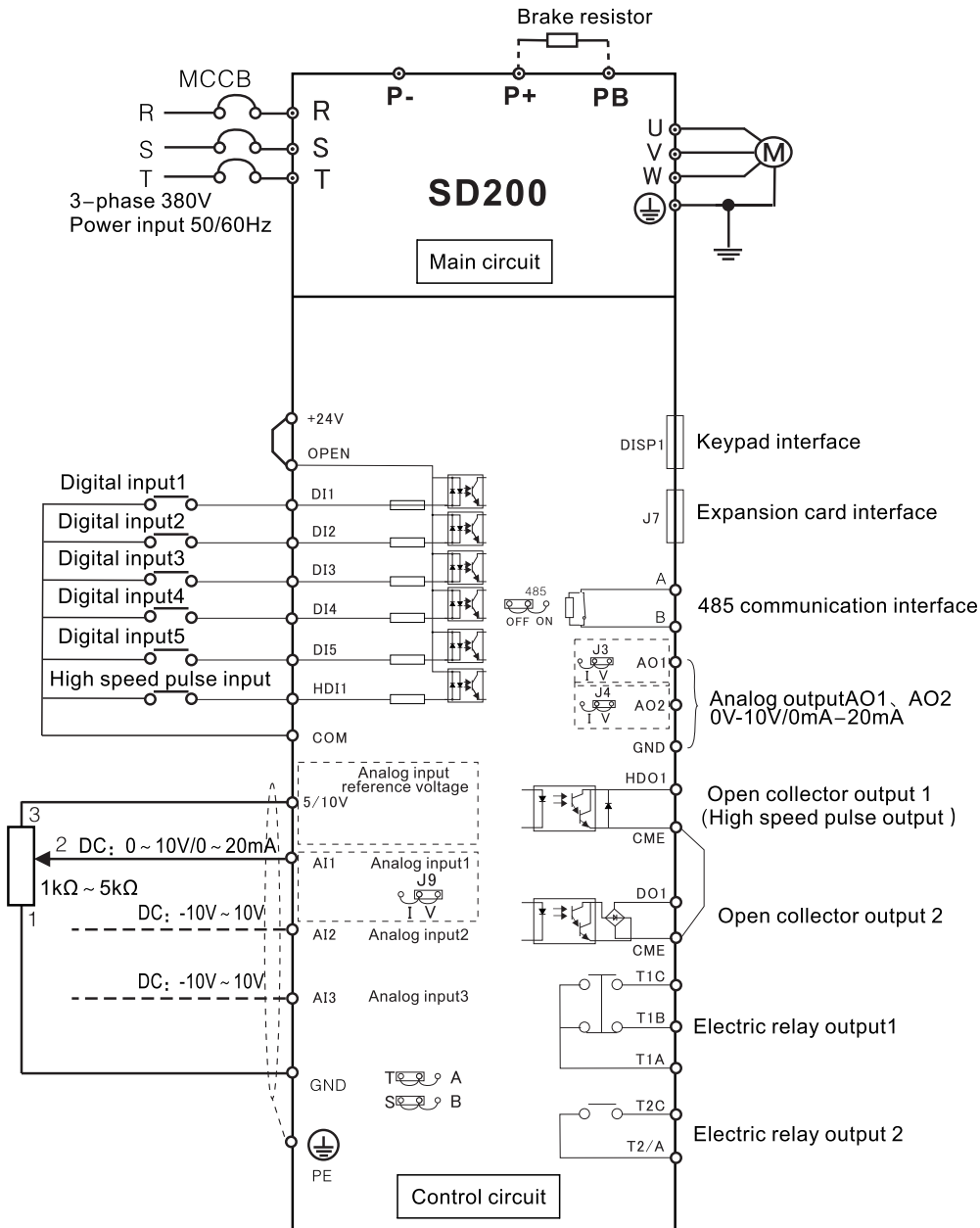

SD200 External Wiring Diagram

Note:

1. SD200 series under 22kw is with standard onboard brake unit and the whole series applies standard RS485 communication interface.
2. This figure is suitable for the machine power level under SD200-4T-18.5G, other power levels please refer to the user manual.
3. The figure "O" is Control circuit terminal "●" is main circuit terminal.





Technical Specification

	Item	Specification
Basic Specification	Max. output frequency	0~600Hz
	Carrier frequency	2.0kHz~10kHz, The carrier frequency is automatically adjusted on the load features.
	Input frequency resolution	Digital setting: 0.01Hz Analog setting: Max. frequency × 0.025%
	Control mode	0: V/F control ; 1: Vector mode 0 control 0
	Speed range	1: 50 1Hz/150% Rated torque
	Overload capability	Type G: 150%Rate current 60/s; Type P: 110%Rate current 60/s
	Torque boost	Auto Torque boost Manual Torque boost 0.1%~20.0%
	V/F curve	Four modes: Line, Multi-point , Square V/F curve, V/F separation
	ACC/DEC curve	Line or S-curve Acc/Dec mode : four kinds of Acc/Dec time. Range of Acc/Dec time : 0.0~6000.0s
	DC brake	DC brake frequency: 0.00Hz~Max. frequency Brake time: 0.0s~100.0s Brake current: 0.0~150.0%
	Jog control	Jog frequency range: 0.00Hz~F00.03Maximum frequency
	Simple PLC Multi-speed running	16-speed operating through built-in PLC or control terminal
	Onboard PID	It realizes process-controlled closed loop control system easily
	Automatic voltage regulation (AVR)	Jog frequency range:0.00Hz~Maximum frequency
Over voltage stall control	The current and voltage are limited automatically during the running process so as to avoid frequent tripping due to overvoltage/overcurrent.	
Rapid current limit	Rapid software and hardware current limiting technology	
Individualized Function	Non stop Function	Load feedback energy compensates the voltage reduction so that the AC drive can continue to run in a short time in case of power interruption.
	Speed tracking start	Identify the speed of rapidly rotating motor to realize a smooth start without any rush.
	Rapid current limiting	Rapid software and hardware current limiting technology helps to avoid frequent over-current fault.
	Virtual IO	Four sets of virtual Do and five sets of virtual DI enable easy logic control
	Timing Control	Timing control function: Set the time range: 0.0Min ~ 6500.0Min
	Multi-motor switch	Two independent motor parameters enable two motors switching control
	Bus Support	Two independent MODBUS communication, Profibus-DP
Motor overheating protection	Optional IO expansion card 1, analog input T_Motor (AI5)analog input AI3 acceptable the input of motor temperature sensor (PT100、PT1000)	
Running	Command source	Given the control panel,control terminal,serial communication port given.It can be switched by a variety of ways.
	Frequency source	11 frequency sources: digital setting,analog voltage setting,analog current setting,pulse setting and serial port. It can be switched by a variety of ways.
	Auxiliary frequency source	11 auxiliary frequency source.Flexible implementation of auxiliary frequency tuning, frequency synthesis.
	Input terminal	Standard: . Six digital input terminals, one of which support to 50kHz high-speed pulse input . Three analog input terminals, two of which supports -10V ~ 10V voltage input . One support 0 ~ 10V voltage input or 0 ~ 20mA current input Expansion capability: . Two digital inputs . One analog input terminal, support -10V ~ 10V voltage input, and supports PT100 / Pt1000
	Output terminal	Standard: . One high-speed pulse output terminal (optional open collector type), support of 0 ~ 50kHz square wave signal output . One digital output terminal . Two relay output terminals . Two analog output terminals, support 0 ~ 20mA current output or 0 ~ 10V voltage output Expansion capability: . One digital output terminal, one relay output terminal . One analog output terminal, support 0 ~ 20mA current output or 0~10V voltage output.





Technical Specification

	Item	Specification
Operational and Display	LED display	Display each parameter of function code group
	Key lock and selection function	Achieve some or all of the keys locked and define the scope of partial keys to prevent misuse.
	Protection function	Powered motor short circuit test; Input/output phase failure protection; Over current protection; voltage protection; Under voltage protection; Over heat protection; Overload protection; braking resistor fault protection.
	Optional parts	Brake unit, Simple IO expansion card, Multi-functional IO expansion card
Environment	Installation location	Indoor, free from direct sunlight, dust, corrosive gas, combustible gas, oil smoke, vapour, drip or salt
	Altitude	Less than 1000m (derated when use of 1000m~3000m)
	Ambient temperature	- 10°C ~ + 40°C (derated when use in ambient temperature of 40°C ~50°C)
	Humidity	Less than 95%RH, without condensation
	Vibration	Less than 5.9m/s ² (0.6g)
	Storage temperature	-20°C~+60°C

Technical Data

Model Number	Power capacity (KVA)	Input current (A)	Output current (A)	Adaptable Motor(KW)	Model Number	Power capacity (KVA)	Input current (A)	Output current (A)	Adaptable Motor(KW)
SD200-2S: 0.7KW-2.2KW					Single-phase220V 50/60Hz				
SD200-2S-0.7G	1.5	8.2	4.7	0.75	SD200-2S-2.2G	4.0	23.0	10.0	2.2
SD200-2S-1.5G	3.0	14.0	7.5	1.5					
SD200-2T: 0.7KW-2.2KW					Three-phase220V 50/60Hz				
SD200-2T-0.7G	1.5	5.5	4.7	0.75	SD200-2T-2.2G	4.0	12.0	10.0	2.2
SD200-2T-1.5G	3.0	7.7	7.5	1.5					
SD200-4T: 0.7KW-500KW					Three-phase380V 50/60Hz				
SD200-4T-0.7G	1.5	3.4	2.3	0.75	SD200-4T-90G	134	180	176	90
SD200-4T-1.5G	3.0	5.0	3.7	1.5	SD200-4T-110G	160	214	210	110
SD200-4T-2.2G	4.0	5.8	5.1	2.2	SD200-4T-132G	192	256	253	132
SD200-4T-4.0G	5.9	10.5	8.5	4.0	SD200-4T-160G	231	307	304	160
SD200-4T-5.5G	8.9	14.6	13	5.5	SD200-4T-185G	255	333	330	185
SD200-4T-7.5G	11	20.5	17	7.5	SD200-4T-200G	287	380	377	200
SD200-4T-11G	17	26	25	11	SD200-4T-220G	311	429	426	220
SD200-4T-15G	21	35	32	15	SD200-4T-250G	355	470	465	250
SD200-4T-18.5G	24	38.5	37	18.5	SD200-4T-280G	396	525	520	280
SD200-4T-22G	30	46.5	45	22	SD200-4T-315G	439	605	600	315
SD200-4T-30G	40	62.5	60	30	SD200-4T-350G	479	665	660	355
SD200-4T-37G	57	76	75	37	SD200-4T-400G	530	730	725	400
SD200-4T-45G	69	92	91	45	SD200-4T-450G	600	825	820	450
SD200-4T-55G	85	113	112	55	SD200-4T-500G	660	910	900	500
SD200-4T-75G	114	157	150	75					





SD200 Outline Diagram

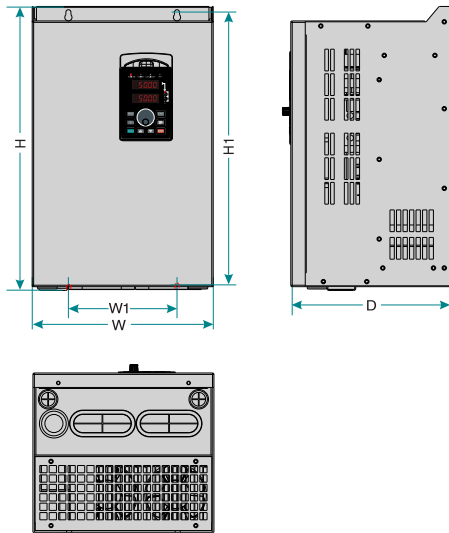

SD200(11KW-45KW)outline and installing dimension

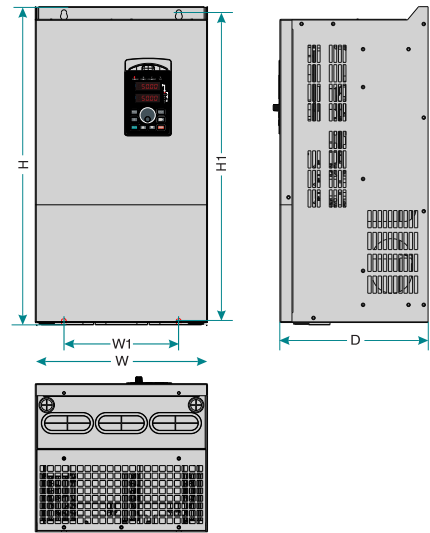

SD200(55KW-110KW) outline and installing dimension

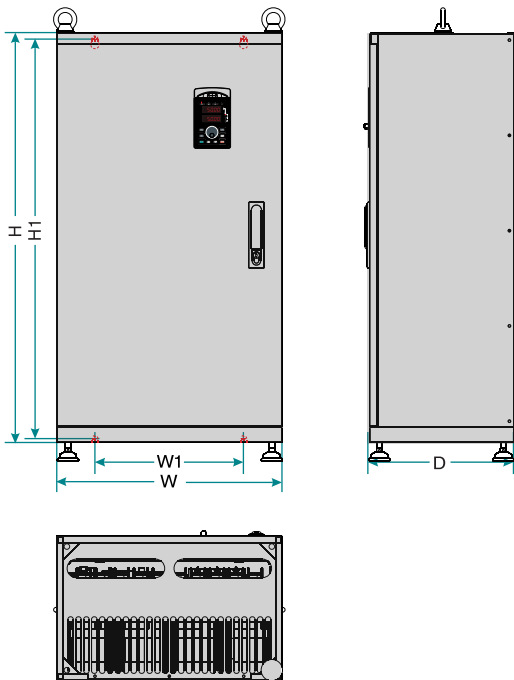

SD200(132KW-185KW)outline and installing dimension

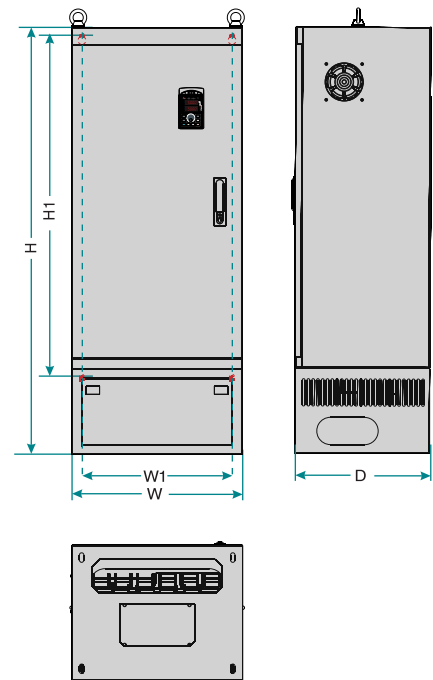

SD200(200KW-500KW)outline and installing dimension





Installation Size

Model Number	H(mm)	W(mm)	D(mm)	H1(mm)	W1(mm)	Bore(mm)	G.W(kg)
SD200-2S :0.7KW-2.2KW Sigle-phase 220V							
SD200-2S-0.7G	190	110	150	178	98	Φ5	2.4
SD200-2S-1.5G	190	110	150	178	98	Φ5	2.4
SD200-2S-2.2G	190	110	150	178	98	Φ5	2.4
SD200-2T :0.7KW-2.2KW Three-phase 220V							
SD200-2T-0.7G	190	110	150	178	98	Φ5	2.4
SD200-2T-1.5G	190	110	150	178	98	Φ5	2.4
SD200-2T-2.2G	190	110	150	178	98	Φ5	2.4
SD200-4T :0.7KW-500KW Three-phase 380V							
SD200-4T0.7G	190	110	150	178	98	Φ5	2.4
SD200-4T-1.5G	190	110	150	178	98	Φ5	2.4
SD200-4T-2.2G	190	110	150	178	98	Φ5	2.4
SD200-4T-4.0G	210	130	160	198	118	Φ5	3.5
SD200-4T-5.5G	250	155	176	236	141	Φ5	4.5
SD200-4T-7.5G	250	155	176	236	141	Φ5	4.5
SD200-4T-11G	285	170	162	270	135	Φ6	5.1
SD200-4T-15G	332	220	214	318	140	Φ	9.3
SD200-4T-18.5G	332	220	214	318	140	Φ7	9.3
SD200-4T-22G	387	250	220	373	150	Φ7	14
SD200-4T-30G	387	250	220	373	150	Φ7	19
SD200-4T-37G	440	270	252	426	180	Φ7	25
SD200-4T-45G	440	270	252	426	180	Φ7	25
SD200-4T-55G	550	300	258	534	200	Φ9	48
SD200-4T-75G	650	370	282	625	250	Φ9	52
SD200-4T-90G	650	370	282	625	250	Φ9	55
SD200-4T-110G	650	370	282	625	250	Φ9	90
SD200-4T-132G	880	485	310	860	320	Φ13	99
SD200-4T-160G	880	485	310	860	320	Φ13	99
SD200-4T-185G	880	485	310	860	320	Φ13	99
SD200-4T-200G	1250	500	400	1000	440	Φ13	167
SD200-4T-220G	1250	500	400	1000	440	Φ13	167
SD200-4T-250G	1250	500	400	1000	440	Φ13	167
SD200-4T-280G	1350	650	400	1105	513	Φ13	206
SD200-4T-315G	1350	650	400	1105	513	Φ13	206
SD200-4T-350G	1350	650	400	1105	513	Φ13	206
SD200-4T-400G	1810	850	405	1410	513	Φ13	415
SD200-4T-450G	1810	850	405	1410	513	Φ13	415
SD200-4T-500G	1810	850	405	1410	513	Φ13	415

Note:

Above dimensions is only for reference. Instructions are subject to change without notice. For more information, please contact SINOVO.





Keyboard/Accessory

01 Keyboard

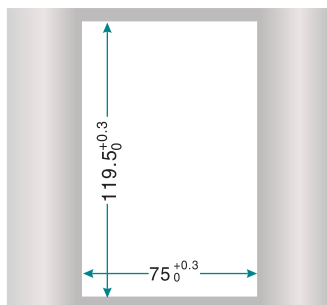
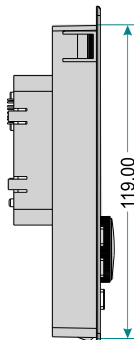
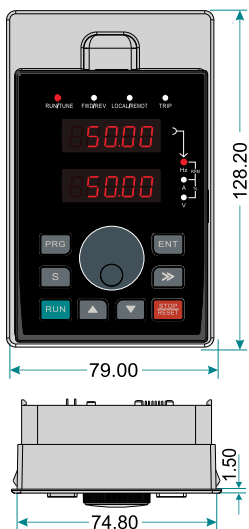

Opening dimension diagram for keyboards with base

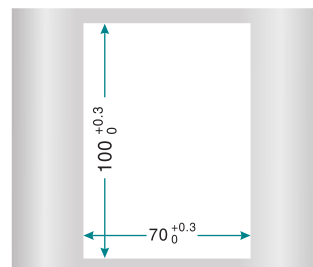

Opening dimension diagram for keyboards without base

02 Optional Accessory

Name	Type	Function	Remark
Internal braking unit	Models followed by letter "C"	Models power under 22KW are installed with the internal braking unit as standard configuration.	For 30KW model power, the braking unit is optional
External braking unit	SDBUN	37KW and above need to be configured with an external braking unit.	Multiple braking units are connected in parallel for the models above 90KW.
Multi-function I / O expansion card	SD200IO1	Increase 3 digital inputs, 2 digital outputs, two relay outputs, two analog voltage input T_Motor.	It applies to all models.
Modbus communication card	SD200CM1	One RS - 485 communication card, one CAN communication card.	Coming soon
External LCD panel	SD200LCD	External LCD display and keypad, you supply copy parameters	Coming soon





Peripheral Equipment

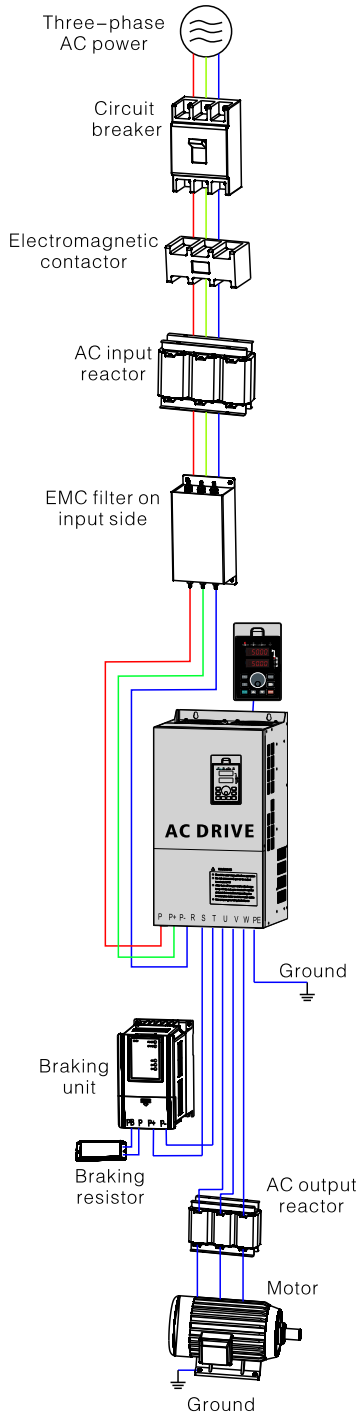

Name	Mounting Location	Function Description
MCCB	Power receiving side	<ul style="list-style-type: none"> ◆ Interrupt the power supply when over-current occurs on downstream devices
Contactor	Between MCCB and AC drive input side	<ul style="list-style-type: none"> ◆ Start and stop the AC drive. Do not start and stop the AC drive frequently by switching the contactor on and off (less than twice per minute) nor use it to directly start the inverter.
AC input reactor	AC drive input side	<ul style="list-style-type: none"> ◆ Improve the power factor of the input side. ◆ Eliminate the higher harmonics of the input side effectively and prevent other devices from being damaged due to distortion of the voltage waveform. ◆ Eliminate the input current unbalanced due to that between the power phases.
EMC Input filter	AC driver input side	<ul style="list-style-type: none"> ◆ Reduce the external conduction and radiation interference of the inverter. ◆ Decrease the conduction interference flowing from the power end to the inverter and improve the anti interference capacity of the AC drive.
DC reactor	SD200 series AC drive under 30G configured with DC reactor as standard	<ul style="list-style-type: none"> ◆ Improve the power factor of the input side. ◆ Improve the efficiency and thermal stability of the AC drive. ◆ Eliminate the impact of higher harmonics of AC drive input side and reduce the external conduction and radiation interference
AC output reactor	Between AC drive output side and the motor, close to the inverter	<ul style="list-style-type: none"> ◆ The output side of the AC drive generally has much higher harmonics. When the motor is far from the AC drive, there is much distributed capacitance in the circuit and certain harmonics may cause resonance in the circuit, bringing about the following two impacts: <ol style="list-style-type: none"> a) Degrade the motor insulation performance and damage the motor in the long run. b) Generate large leakage current and cause frequent AC drive protection trips. ◆ If the distance between the inverter and the motor is greater than 100 m, install an AC output reactor.





Braking Unit Recommendation

01

Selection of value resistance

The motor and load's regenerative energy is almost completely consumed on the braking resistor when braking. According to the formula:

$$U \cdot U/R = P_b$$

U---Braking voltage at stable braking system. System selections differs in braking voltages, The AC380V system usually selects DC700V braking voltage.)

P_b---Braking power

02

Selection of Braking Resistance Power

Theoretically braking resistance of power and braking power is consistent, but considering the derating 70%. According to the formula:

$$0.7 \cdot P_r = P_b \cdot D$$

P_r---Resistor power

D---Braking frequency (The reproduction process accounts for the proportion of the entire working process)

Elevator---20%~30%

Open and draw volume---20%~30%

Centrifuge---50%~60%

Accidental braking load---5% Commonly take 10%

SD200 series AC Drive braking unit selection table

AC Drive Capacity (KW)	Braking Unit		Braking resistance		
	Specification	Q.T.Y (unit)	Recommended Resistance	Recommended Power	Q.T.Y (unit)
0.75	Standard onboard	1	≥300Ω	150W	1
1.5		1	≥220Ω	150W	1
2.2		1	≥200Ω	250W	1
4.0		1	≥130Ω	300W	1
5.5		1	≥90Ω	400W	1
7.5		1	≥65Ω	500W	1
11		1	≥40Ω	800W	1
15		1	≥32Ω	1000W	1
18.5		1	≥25Ω	1300W	1
22		1	≥22Ω	1500W	1
30		1	≥16Ω	2500W	1
37		EHBU70	1	≥16Ω	3700W
45	1		≥16Ω	4500W	1
55	1		≥8Ω	5500W	1
75	2		≥8Ω	3700W	2
90	2		≥8Ω	4500W	2
110	2		≥8Ω	5500W	2
132	3		≥8Ω	3700W	3
160	3		≥8Ω	5500W	3
185	4		≥8Ω	4500W	4
200	4		≥8Ω	5500W	4
220	4	≥8Ω	5500W	4	

